

EXPANSION JOINT FOR PLASTIC CONDUIT

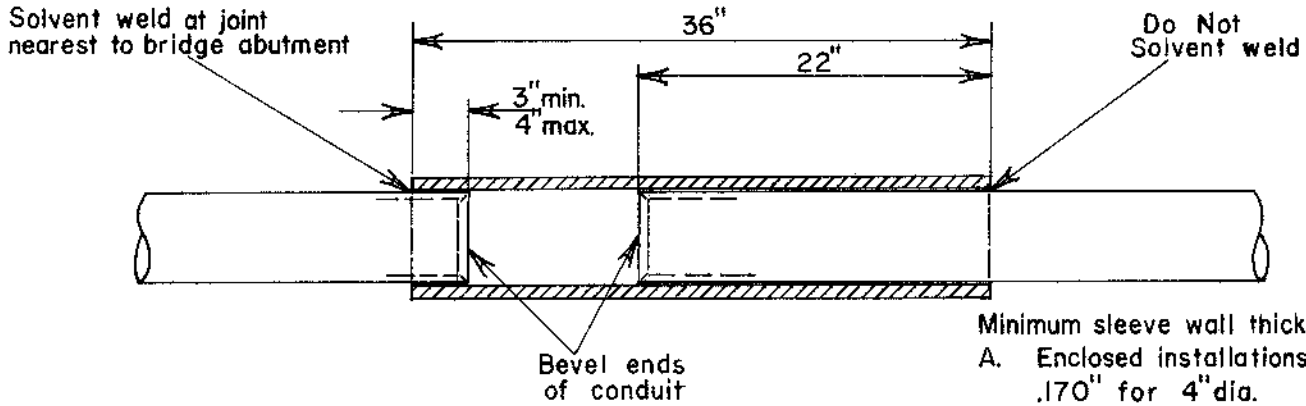

Minimum sleeve wall thickness for:

A. Enclosed installations
 .170" for 4" dia.
 .190" for 5" dia.
 .200" for 6" dia.

B. Exposed installations
 .337" for 4" dia.
 .375" for 5" dia.
 .432" for 6" dia.

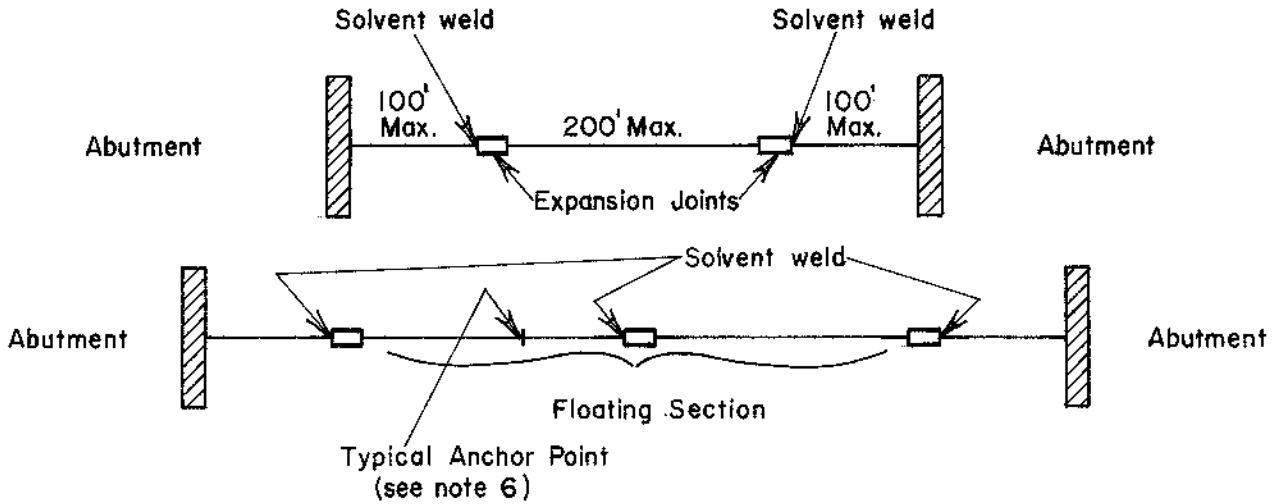

NOTES:

1. The expansion joint is a length of coupling stock extruded from the same material as the conduit that it joins.
2. The mating ends of conduit shall be beveled to provide a smooth transition within the joint.
3. The expansion joint shall be solvent welded 3 to 4 inches onto one end of the conduit.
4. The mating end of the conduit shall then be positioned 22" into the free end of the expansion joint. Do not solvent weld.
5. Install all expansion joints a minimum of 2 feet clear of all spacers, supports or straps.
6. Install the expansion joint within 100 feet of the bridge abutment. When more than two expansion joints are required, all "floating" conduit must be anchored to prevent longitudinal movement. Floating conduit should be anchored at one point only; this usually is best accomplished by tightening the spacer at the conduit support nearest the expansion joint.

RIVERSIDE PUBLIC UTILITIES DEPT. - UNDERGROUND STRUCTURES

Wesley D. Campbell
 Approved - Chief Engineer

Latest Revision: **Redrawn**

UGS-141